

P3D188

・ON

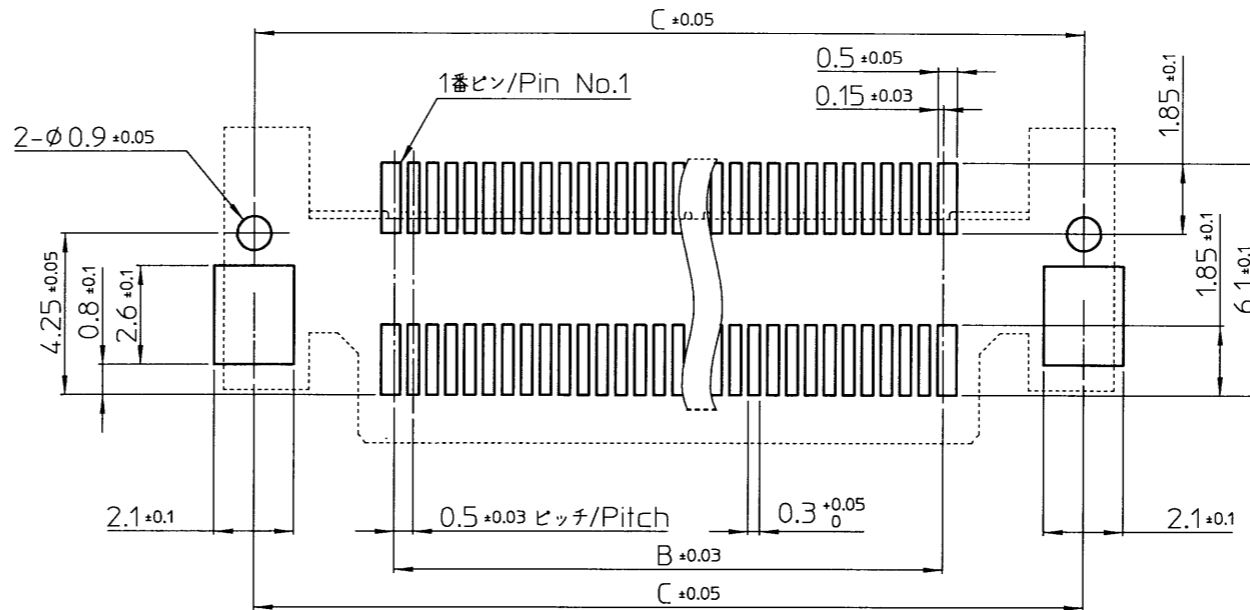
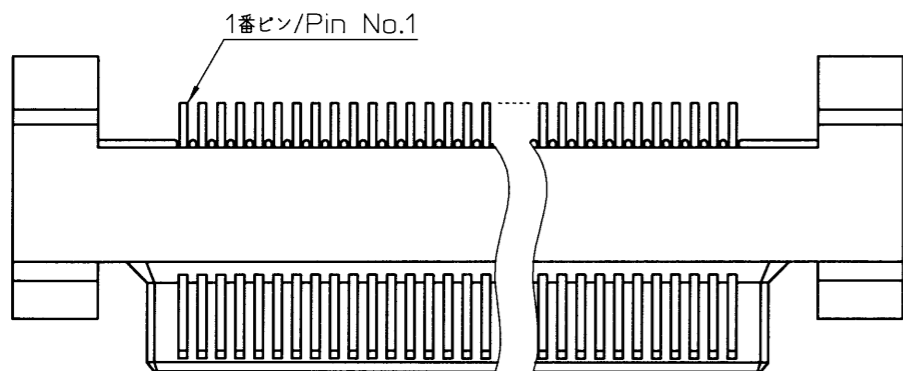

参考基板設計要領 (コネクタ搭載面)

A reference drawing of P.W.B(Connector mounting side)

極数 No. of contacts	A	B	C	D
030	8.9	7.0	14.4	16.0
040	11.4	9.5	16.9	18.5
050	13.9	12.0	19.4	21.0
060	16.4	14.5	21.9	23.5
080	21.4	19.5	26.9	28.5
100	26.4	24.5	31.9	33.5
120	31.4	29.5	36.9	38.5
140	36.4	34.5	41.9	43.5

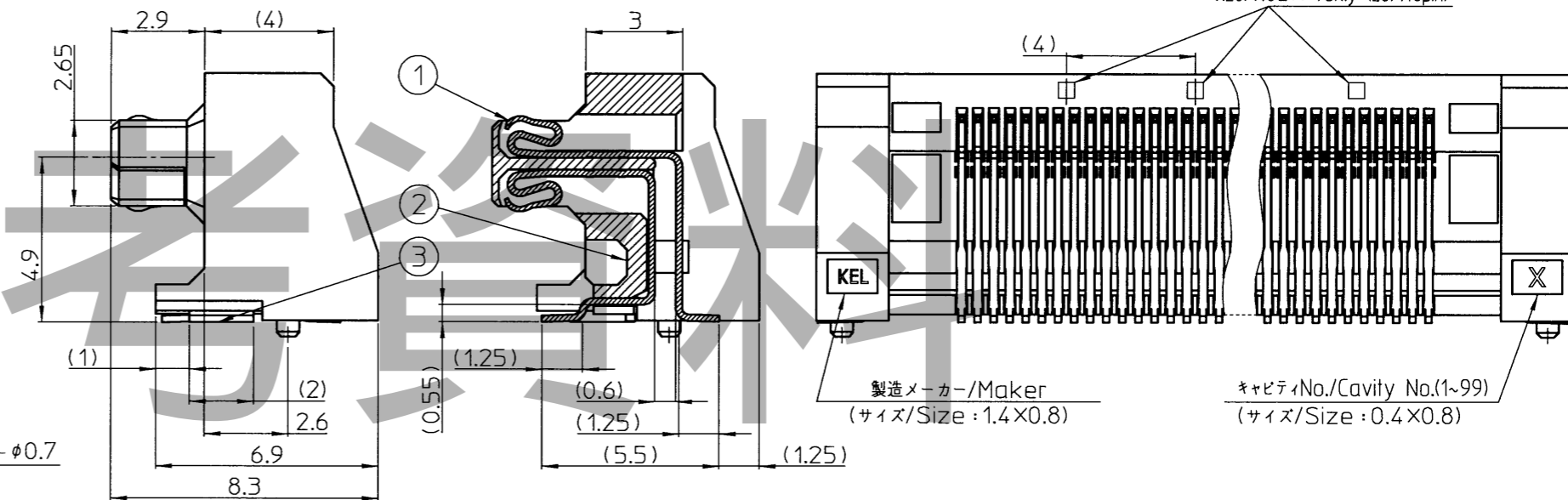
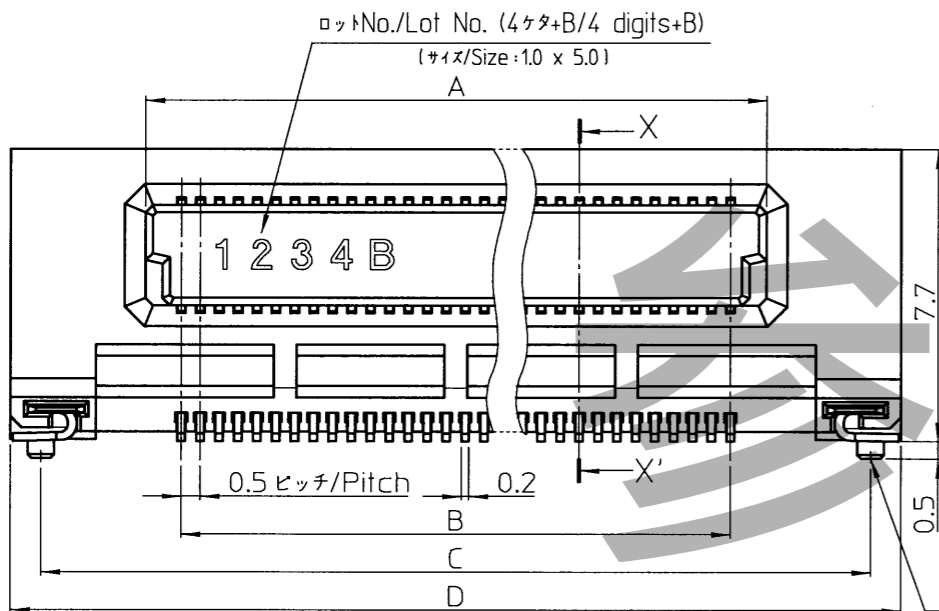

X-X' Cross-section

NOTES

- 指定無き寸法公差/Unless otherwise specified, tolerances shall be.
 0~10未満/Less than 10 ±0.2
 10~50 ±0.25
- コプラナリティ/Coplanarity
 コンタクト及び固定金具のテール部のバラツキ:0.1以下
 /Variation of tail in contact and retention clip:0.1MAX.

DY10-□□□ L B

- B:接触部0.1μm以上/Contact area 0.1μm or more
 テール部0.03μm以上/Tail area 0.03μm or more
- テール形状/Shape of Tail
 L:ライトアングルタイプ/Right angle Type
- 極数/Number of contacts
 030: 30極/30pin 040: 40極/40pin 050: 50極/50pin
 060: 60極/60pin 080: 80極/80pin 100:100極/100pin
 120:120極/120pin 140:140極/140pin
- シリーズ名/Series name
 DY10:プラグ #ス無し/Plug without Boss
 DY11:プラグ #ス有り/Plug with Boss

No.	品名 /Part name	数量 /Quantity	材質/Material	仕上げ/Finish
③	固定金具 /Retention clip	2	銅合金/Copper alloy	ニッケルメッキ下地, Au0.03μm以上 /Under plating Nickel, Au0.03μm or more
②	インシュレータ /Insulator	1	L.C.P.(UL94V-0)黒 ガラス繊維入り Glass-filled L.C.P.(UL94V-0),Black	
①	コンタクト /Contact	極数 /No.of contacts	銅合金/Copper alloy	ニッケルメッキ下地, Au0.1μm以上(接触部), Au0.03μm以上(テール部) /Under plating Nickel, Au0.1μm or more(contact area), Au0.03μm or more(tail area)

△ x				
△ x				
△ x				
REV. DATE	APPROVED BY	CHECKED BY	DRAWN BY	DESCRIPTION
Oct.25,2018	<i>A.Hanaga</i>	<i>M.Kobayashi</i>	J.Tanaka	品種追加/Added part number.
THIRD ANGLE PROJECTION	DRAWN BY	DATE	CHECKED BY	DATE
	M.Kobayashi	Jul.16,2015	M.Koizumi	Jul.16,2015
APPROVED BY				DATE
A.Kasuga				Jul.17,2015
SCALE				UNIT
5:1				mm
MATERIAL			TITLE	
			DY10-□□□LB	
DRAWING No.				REVISION
P3D188				3